

101-MILLIMETER COMPATIBLE SWIPE READER TECHNICAL REFERENCE MANUAL

Part Number 99821101-6

JULY 2003

MAGTEK[®]

REGISTERED TO ISO 9001:2000

20725 South Annalee Avenue

Carson, CA 90746

Phone: (310) 631-8602

FAX: (310) 631-3956

Technical Support: (651) 415-6800

www.magtek.com

Information in this document is subject to change without notice. No part of this document may be reproduced or transmitted in any form or by any means, electronic or mechanical, for any purpose, without the express written permission of MagTek, Inc.

MagTek is a registered trademark of MagTek, Inc.

REVISIONS

Rev Number	Date	Notes
1	1989	Initial Release
2	22 Oct 99	Formatted manual; Added IEC requirements to Specifications; Changed values in Specifications; Clarified Connector information; Added correct drawings; Clarified Card Present Signal
3	14 Sep 00	Section 1, Specs Corrected length dimension to 101.6 mm. Written to <i>SI, International System of Units</i> .
4	25 Jul 01	Front Matter: Added to Agency page: FCC Class B, UL and CUL, CE Class B. Copyright 2001 added.
5	08 Apr 03	Front Matter: added ISO line to logo, changed Tech Support phone number, added new warranty, changed warranty from 90 days to 1 year.
6	16 Jul 03	Sec 1: added cable length to Configuration Table and deleted P/N 21050149 and added 21050005, added MTBF Electronics to Specification Table, changed power requirements to 2.7 VDC, and corrected units. Table 2-1, 2-2, and 2-3 added mating connectors and changed V _{cc} from 2.4 to 2.7. Table 2-1 corrected color-coding for pin 6.

Limited Warranty

MagTek, Inc. warrants that the Product described in this document is free of defects in materials and workmanship for a period of one year from the date of purchase where the date of purchase is defined as the date of shipment from MagTek. During this warranty period, MagTek shall, at their option, repair or replace without charge for either parts or labor, any failure, malfunction, defect or nonconformity which prevents the product from performing in accordance with MagTek's published technical specifications and manuals.

This warranty does not apply to wear of the magnetic read head. This warranty shall not apply if the product is modified, tampered with, or subject to abnormal working conditions. This warranty does not apply when the malfunction results from the use of the Product in conjunction with ancillary or peripheral equipment where it is determined by MagTek that there is no fault in the Product itself.

Notification by the Customer to MagTek of any condition described above should be directed to the Customer's MagTek Sales Representative or to MagTek's Help Desk at (651) 415-6800. If the Product is to be returned from the Customer to MagTek, a returned material authorization (RMA) will be issued by MagTek. The Customer shall be responsible for shipping charges to MagTek, (20801 S. Annalee Ave., Carson, CA 90746). MagTek shall be responsible for shipping charges back to the Customer.

Repair or replacement as provided under this warranty is the exclusive remedy. This warranty is in lieu of all other warranties, express or implied.

FCC WARNING STATEMENT

This equipment has been tested and found to comply with the limits for Class B digital device, pursuant to Part 15 of FCC Rules. These limits are designed to provide reasonable protection against harmful interference when the equipment is operated in a residential environment. This equipment generates, uses, and can radiate radio frequency energy and, if not installed and used in accordance with the instruction manual, may cause harmful interference to radio communications. However, there is no guarantee that interference will not occur in a particular installation.

FCC COMPLIANCE STATEMENT

This device complies with Part 15 Of The FCC Rules. Operation of this device is subject to the following two conditions: (1) This device may not cause harmful interference. And (2) This device must accept any interference received, including interference that may cause undesired operation.

CANADIAN DOC STATEMENT

This digital apparatus does not exceed the Class B limits for radio noise for digital apparatus set out in the Radio Interference Regulations of the Canadian Department of Communications.

Le présent appareil numérique n'émet pas de bruits radioélectriques dépassant les limites applicables aux appareils numériques de la classe B prescrites dans le Règlement sur le brouillage radioélectrique édicté par le ministère des Communications du Canada.

CE STANDARDS

Testing for compliance to CE and FCC requirements was performed by an independent laboratory. The unit under test was found compliant to Class B.

UL/CSA

This product is recognized per Underwriter Laboratories and Canadian Underwriter Laboratories 1950.

TABLE OF CONTENTS

SECTION 1. FEATURES AND SPECIFICATIONS	1
CONFIGURATIONS.....	1
REFERENCE DOCUMENT	1
SPECIFICATIONS	2
SECTION 2. INSTALLATION	3
MOUNTING.....	3
CONNECTORS.....	5
TIMING.....	6
DATA.....	7
STROBE	7
CARD PRESENT	7

FIGURES

Figure 1-1. 101-millimeter Compatible Swipe Reader	vi
Figure 2-1. Reader Mounting Dimensions With Cover.....	3
Figure 2-2. Reader Mounting Dimensions Without Cover	4
Figure 2-3. Timing	6

TABLES

Table 2-1. I/O Connector for Single Track, 6 Pin.....	5
Table 2-2. I/O Connector for Dual Track, 8 Pin.....	5
Table 2-3. I/O Connector for 3 Track, 10 Pin.....	6

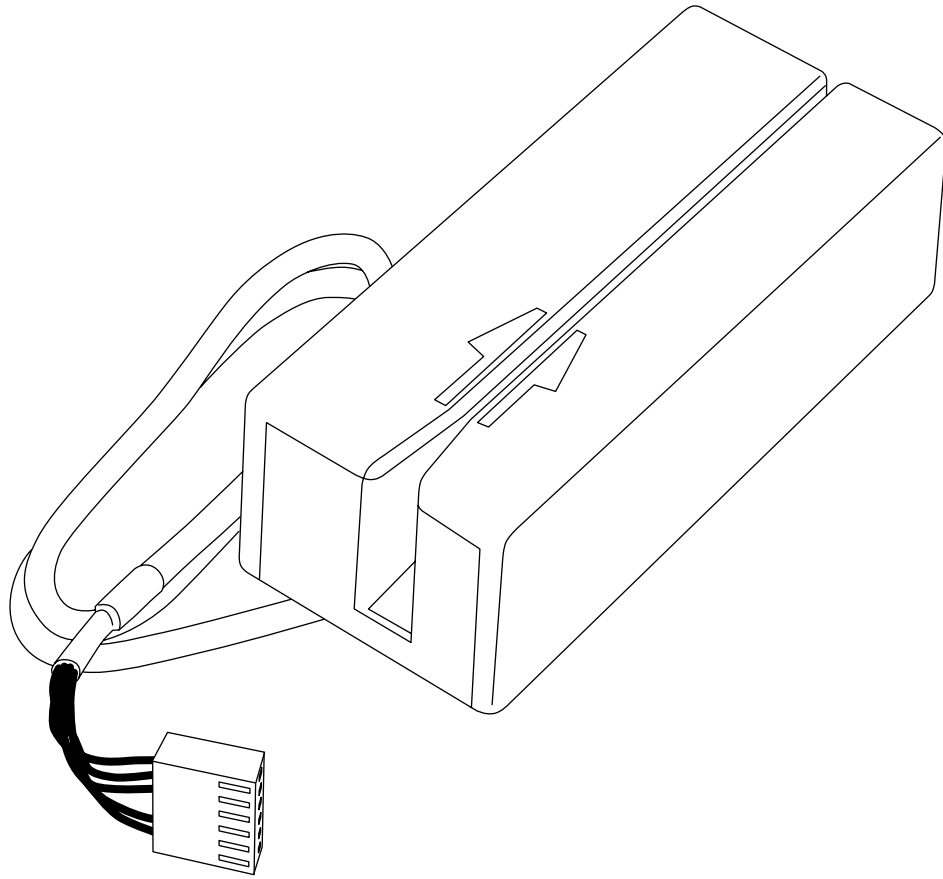

Figure 1-1. 101-millimeter Compatible Swipe Reader

SECTION 1. FEATURES AND SPECIFICATIONS

The 101-millimeter OEM Swipe Reader has a TTL level interface and is designed for use in retail, access control, and time and attendance environments. This Reader is in compliance with industry specifications, including ANSI/ISO Standards 7810, 7811-1 through -6, 7812, 7813, and AAMVA. The Reader can be customized. Bidirectional read capability is available.

CONFIGURATIONS

	Part Number	Read	Color	Cable Length
Integral Electronics, Single Track with Cover	21050001	Track 1	Black	20"
	21050002	Track 2	Black	20"
	21050003	Track 3	Black	20"
Integral Electronics, Single Track without Cover	21050058	Track 1	Black	7"
	21050057	Track 2	Black	21"
Integral Electronics, Dual Tracks with Cover	21050004	Tracks 1 & 2	Black	20"
	21050005	Tracks 2 & 3	Black	20"
Integral Electronics, 3 Tracks with Cover	21050145	Tracks 1,2, & 3	Black	20"

REFERENCE DOCUMENT

I/O Interface for TTL Swipe Readers, Technical Reference Manual, P/N 99875148

SPECIFICATIONS

IEC: Meets or Exceeds Requirements for:	IEC 1000-4-2 ESD (Electro Static Discharge) IEC 1000-4-3 Radiated EMC Field (2X requirement) IEC 1000-4-4 Electrical Fast Transient Burst requirement (transmission on I/O cable)
Flammability	Meets UL94V-0
Recording Method	Two-Frequency Coherent Phase (F2F)
Speed	Card speed through the unit may vary from: 2 to 125 in/s at 75 bpi (5.1 to 318 cm/s at 29.5 b/cm) 2 to 60 in/s at 210 bpi (5.1 to 152.4 cm/s at 82.7b/cm)
Power Requirements	Single Track: 2.7 to 5.5Vdc at 1 mA, typical Dual Track: 2.7 to 5.5Vdc at 2 mA, typical 3 Tracks: 2.7 to 5.5Vdc at 3 mA, typical
Output Signal Levels	$V_{ol} = 0.4 \text{ VDC}$ at 2 mA $V_{oh} = V_{cc} - 0.5 \text{ VDC}$ at -2 mA
Operating Temperature	-30 °C to 70 °C
Operating Humidity	10% to 90% relative humidity
Life	300,000 passes Single Track 1,000,000 passes Multi-Track
MTBF Electronics	125,000 h
Dimensions	Length: 4.0" (101.6 mm) Height: 1.08" (27.4 mm) Width: 1.62" (41.1 mm)
Cable Length, Standard:	Single Track: 20" (508.0 mm) Dual Track: 20" (508.0 mm) 3 Track 20" (508.0 mm) Consult Factory for other lengths
Connector	See Section 2, Connectors
Colors available	Black, Standard Pearl White Available

SECTION 2. INSTALLATION

This section consists of installation and checkout of the Reader.

MOUNTING

The dimensions for mounting with the cover are shown in Figure 2-1.

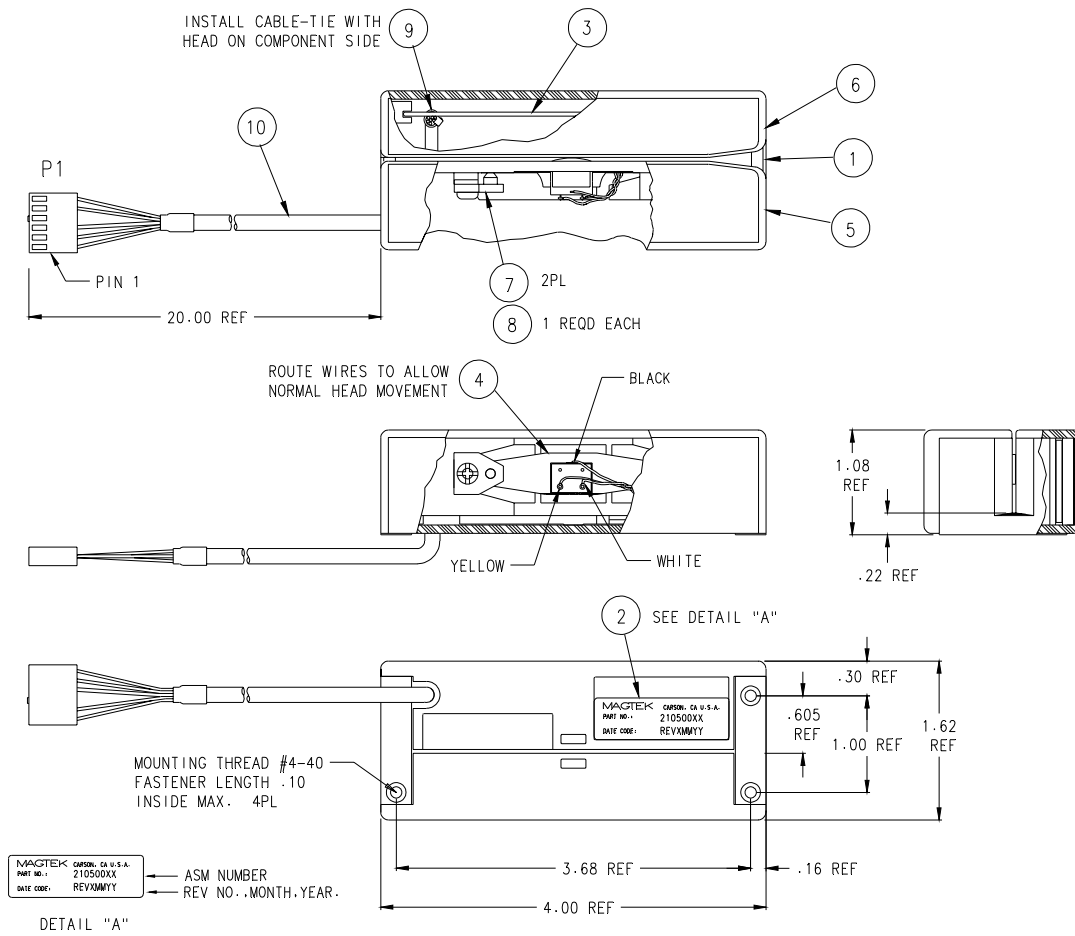

Figure 2-1. Reader Mounting Dimensions With Cover

101-Millimeter Compatible Swipe Reader

The dimensions for mounting without the cover are shown in Figure 2-2.

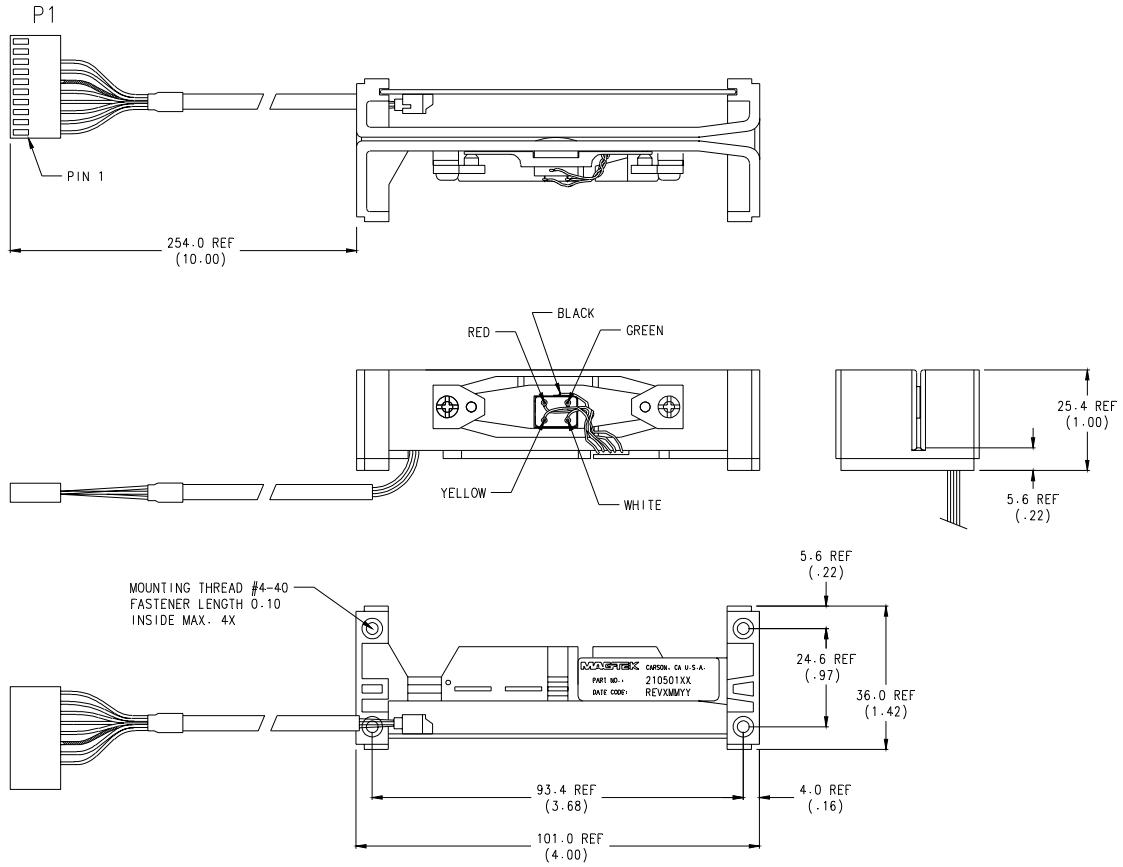

Figure 2-2. Reader Mounting Dimensions Without Cover

CONNECTORS

Single Track I/O Connector is shown in Table 2-1, and the Dual Track I/O Connector is shown in Table 2-2.

Table 2-1. I/O Connector for Single Track, 6 Pin

	Pin Number	Color	Signal
Connector for Single Track, 6 Pin Molex 6 Pin 22-01-2061 0.100 inch Contact Spacing Mates to Molex 22-05-2061	1	Yellow	$\overline{\text{DATA}}$
	2	Orange	$\overline{\text{CARD PRESENT}}$
	3	Green	$\overline{\text{STROBE}}$
	4	–	KEY
	5	Red	V_{cc}
	6	Brown	GND

Note: V_{cc} = 2.7 to 5.5 VDC

Table 2-2. I/O Connector for Dual Track, 8 Pin

	Pin Number	Color	Signal
Connector for Dual Track, 8 Pin Molex 8 Pin 22-01-2081 0.100 inch Contact Spacing Mates to Molex 22-05-2081	1	Yellow	$\overline{\text{DATA (Tk 2)}}$
	2	White	$\overline{\text{CARD PRESENT}}$
	3	Green	$\overline{\text{STROBE (Tk 2)}}$
	4	–	KEY
	5	Red	V_{cc}
	6	Black	GND
	7	Blue	$\overline{\text{STROBE (Tk 1 or Tk 3)}}$
	8	Brown	$\overline{\text{DATA (Tk 1 or Tk 3)}}$

Note: V_{cc} = 2.7 to 5.5 VDC

Table 2-3. I/O Connector for 3 Track, 10 Pin

	Pin Number	Color	Signal
Connector for 3 Track, 10 Pin Molex 10 Pin 22-01-2101 0.100 inch Contact Spacing Mates to Molex 22-05-2101	1	Yellow	$\overline{\text{DATA (Tk 2)}}$
	2	White	$\overline{\text{CARD PRESENT}}$
	3	Green	$\overline{\text{STROBE (Tk 2)}}$
	4		KEY
	5	Red	V_{cc}
	6	Black	GND
	7	Blue	$\overline{\text{STROBE (Tk 1)}}$
	8	Brown	$\overline{\text{DATA (Tk 1)}}$
	9	Gray	$\overline{\text{STROBE (Tk 3)}}$
	10	Orange	$\overline{\text{DATA (Tk 3)}}$

Note: $V_{cc} = 2.7$ to 5.5 VDC

TIMING

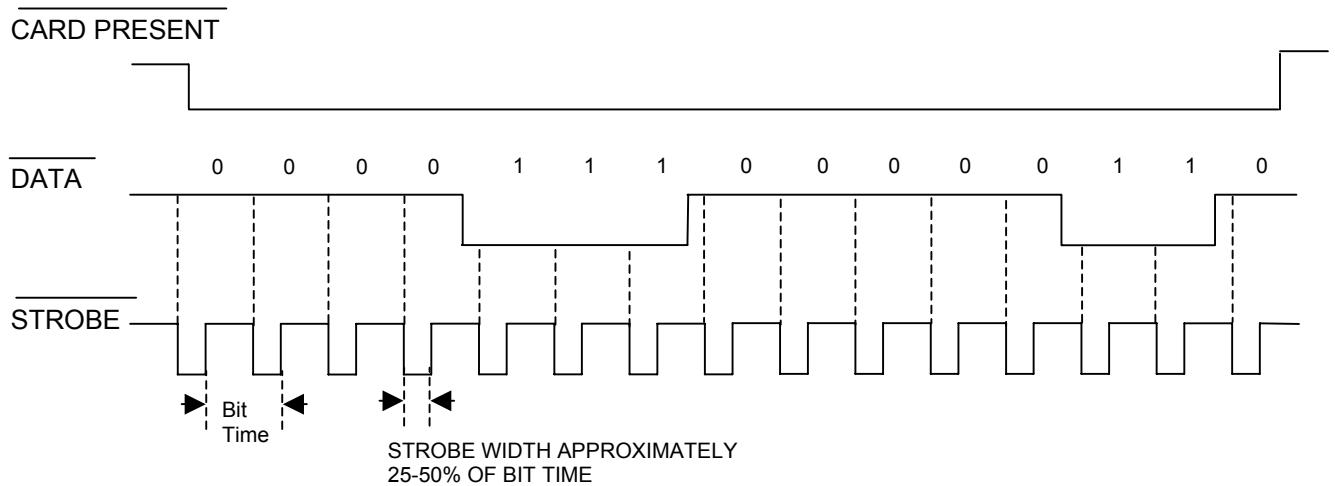

Notes:

1. Time out of the $\overline{\text{CARD PRESENT}}$ signal occurs approximately 150 ms after the last strobe transition.
2. $\overline{\text{DATA}}$ is valid 1.0 μ sec before the negative edge of $\overline{\text{STROBE}}$.

Figure 2-3. Timing

DATA

The Data signal is valid while the strobe is low. If the Data signal is high, the bit is a zero. If the Data signal is low, the bit is a one.

STROBE

The Strobe signal indicates when Data is valid. It is recommended that Data be loaded by the user with the leading edge (negative) of the Strobe.

CARD PRESENT

Card Present will go low after 14/15 flux reversals from the head. Card Present will return high 150 milliseconds after the last flux reversal.

When no card is being moved through the unit, the Data, Strobe, and Card Present signals are high. The signal timing diagram shown above represents the data along with other signals that are generated during the reading process.

101-Millimeter Compatible Swipe Reader
